



AT-FS708
AT-FS708E

Fast Ethernet Switches

Installation Guide

Copyright ©1999 Allied Telesyn International, Corp.
960 Stewart Drive Suite B, Sunnyvale CA 94086, USA

All rights reserved. No part of this publication may be reproduced without prior written permission from Allied Telesyn International, Corp.

Ethernet is a registered trademark of Xerox Corporation. All other product names, company names, logos or other designations mentioned herein are trademarks or registered trademarks of their respective owners.

Allied Telesyn International, Corp. reserves the right to make changes in specifications and other information contained in this document without prior written notice. The information provided herein is subject to change without notice. In no event shall Allied Telesyn International, Corp. be liable for any incidental, special, indirect, or consequential damages whatsoever, including but not limited to lost profits, arising out of or related to this manual or the information contained herein, even if Allied Telesyn International, Corp. has been advised of, known, or should have known, the possibility of such damages.

Electrical Safety and Installation Requirements

STANDARDS: This product meets the following standards

U.S. Federal Communications Commission

RADIATED ENERGY

Note: This equipment has been tested and found to comply with the limits for a Class A digital device pursuant to Part 15 of FCC Rules. These limits are designed to provide reasonable protection against harmful interference when the equipment is operated in a commercial environment. This equipment generates, uses, and can radiate radio frequency energy and, if not installed and used in accordance with this instruction manual, may cause harmful interference to radio communications. Operation of this equipment in a residential area is likely to cause harmful interference in which case the user will be required to correct the interference at his own expense.

Note: Modifications or changes not expressly approved of by the manufacturer or the FCC, can void your right to operate this equipment.

Canadian Department of Communications

This Class A digital apparatus meets all requirements of the Canadian Interference-Causing Equipment Regulations.

Cet appareil numérique de la classe A respecte toutes les exigences du Règlement sur le matériel brouilleur du Canada.

WARNING: In a domestic environment this product may cause radio interference in which case the user may be required to take adequate measures.

RFI Emission

EN55022 Class A

WARNING: This product requires shielded cables to comply with Class A emission limits. If not used with shielded cables, this product may cause radio interference in which case the user may be required to take adequate measures.

Immunity

EN50082-1



SAFETY

ELECTRICAL NOTICES

WARNING: ELECTRIC SHOCK HAZARD

To prevent ELECTRIC shock, do not remove cover. No user-serviceable parts inside. This unit contains HAZARDOUS VOLTAGES and should only be opened by a trained and qualified technician. To avoid the possibility of ELECTRIC SHOCK disconnect electric power to the product before connecting or disconnecting the LAN cables.



LIGHTNING DANGER

DANGER: DO NOT WORK on equipment or CABLES during periods of LIGHTNING ACTIVITY.

INSTALLATION

ELECTRICAL—AUTO VOLTAGE ADJUSTMENT

This product will automatically adjust to any voltage between the ranges shown on the label.

ELECTRICAL—TYPE CLASS 1 EQUIPMENT

THIS EQUIPMENT MUST BE EARTHED. Power plug must be connected to a properly wired earth ground socket outlet. An improperly wired socket outlet could place hazardous voltages on accessible metal parts.

ELECTRICAL—CORD NOTICE

Use power cord, maximum 4.5 meters long, rated 6 amp minimum, 250V, made of HAR cordage molded IEC 320 connector on one end and on the other end a plug approved by the country of end use.



CAUTION: Air vents must not be blocked and must have free access to the room ambient air for cooling.

OPERATING TEMPERATURE

This product is designed for a maximum ambient temperature of 40 degrees C.

ALL COUNTRIES: Install product in accordance with local and National Electrical Codes.

NORMEN: Dieses Produkt erfüllt die Anforderungen der nachfolgenden Normen.

WARNING: Bei Verwendung zu Hause kann dieses Produkt Funkstörungen hervorrufen. In diesem Fall müßte der Anwender angemessene Gegenmaßnahmen ergreifen.

Hochfrequenzstörung EN55022 Klasse A

WARNING: Dieses Produkt muß mit entstörten Kabeln versehen sein, damit es den Emissionsgrenzen der Klasse A entspricht. Wenn dieses Produkt nicht mit entstörten Kabeln verwendet wird, könnte es Funkstörungen hervorrufen; der Anwender müßte in diesem Fall angemessene Gegenmaßnahmen ergreifen.

Störsicherheit EN50082-1



SICHERHEIT

ACHTUNG: GEFÄHRLICHE SPANNUNG

Das Gehäuse nicht öffnen. Das Gerät enthält keine vom Benutzer wartbaren Teile. Das Gerät steht unter Hochspannung und darf nur von qualifiziertem technischem Personal geöffnet werden. Vor Anschluß der LAN-Kabel, Gerät vom Netz trennen.



GEFAHR DURCH BLITZSCHLAG

GEFAHR: Keine Arbeiten am Gerät oder an den Kabeln während eines Gewitters ausführen.

INSTALLATION

AUTOMATISCHE SPANNUNGSEINSTELLUNG

Dieses Gerät stellt sich automatisch auf die auf dem Etikett aufgeführten Spannungswerte ein.

GERÄTE DER KLASSE 1

DIESE GERÄTE MÜSSEN GEERDET SEIN. Der Netzstecker darf nur mit einer vorschriftsmäßig geerdeten Steckdose verbunden werden. Ein unvorschriftsmäßiger Anschluß kann die Metallteile des Gehäuses unter gefährliche elektrische Spannungen setzen.

NETZKABEL

Das Netzkabel sollte eine maximale Länge von 4,5 Metern, einen Nennwert von mindestens 6 A und 250 V haben, aus HAR-Material hergestellt und mit einer gepreßten, IEC 320 entsprechenden, Anschlußverbindung an einem Ende, und am anderen Ende mit einem im Land des Endverbrauchers geprüften Stecker ausgestattet sein.



VORSICHT

Die Entlüftungsöffnungen dürfen nicht versperrt sein und müssen zum Kühlen freien Zugang zur Raumluft haben.

BETRIEBSTEMPERATUR

Dieses Produkt wurde für den Betrieb in einer Umgebungstemperatur von nicht mehr als 40° C entworfen.

ALLE LÄNDER: Installation muß örtlichen und nationalen elektrischen Vorschriften entsprechen.

STANDARDE: Dette produkt tilfredsstiller de følgende standarder.

ADVARSEL: I et hjemligt miljø kunne dette produkt forårsage radio forstyrrelse. Bliver det tilfældet, påkræves brugeren muligvis at tage tilstrækkelige foranstaltninger.

Radiofrekvens forstyrrelsesemission EN55022 Klasse A

ADVARSEL: Der skal bruges skærmbkabler med dette produkt for at opfylde Klasse A emissionsgrænser. Hvis skærmbkabler ikke bruges, kan dette produkt muligvis forårsage radio forstyrrelse. Bliver dette tilfældet, påkræves brugeren muligvis at tage tilstrækkelige foranstaltninger.

Immunitet EN50082-1



SIKKERHED

ELEKTRISKE FORHOLDSREGLER

ADVARSEL: RISIKO FOR ELEKTRISK STØD

For at forebygge ELEKTRISK stød, undlad at åbne apparatet. Der er ingen indre dele, der kan repareres af brugeren. Denne enhed indeholder LIVSFARLIGE STRØMSPÆNDINGER og bør kun åbnes af en uddannet og kvalificeret tekniker. For at undgå risiko for ELEKTRISK STØD, afbrydes den elektriske strøm til produktet, før LAN-kablerne monteres eller afmonteres.



FARE UNDER UVEJR

FARE: UNDLAD at arbejde på udstyr eller KABLER i perioder med LYNAKTIVITET.

INSTALLATION

ELEKTRISK—AUTOMATISK SPÆNDINGSREGULERING

Dette apparat vil automatisk tilpasse sig enhver spænding indenfor de værdier, der er angivet på etiketten.

ELEKTRISK—KLASSE 1-UDSTYR

DETTE UDSTYR KRÆVER JORDFORBINDELSE. Stikket skal være forbundet med en korrekt installeret jordforbunden stikkontakt. En ukorrekt installeret stikkontakt kan sætte livsfarlig spænding til tilgængelige metaldele.

ELEKTRISK—EDNING

Anvend ledning af maksimum 4,5 meters længde, med en kapacitet på minimum 6 amp., 250 v, bestående af en IEC 320 connector med indstøbt HAR ledning i den ene ende og et stik i den anden ende, der er godkendt af myndighederne i brugerlandet.



ADVARSEL: Ventilationsåbninger må ikke blokeres og skal have fri adgang til den omgivende luft i rummet for afkøling.

BETJENINGSTEMPERATUR

Dette apparat er konstrueret til en omgivende temperatur på maksimum 40 grader C.

ALLE LANDE: Installation af produktet skal ske i overensstemmelse med lokal og national lovgivning for elektriske installationer.

EISEN: Dit product voldoet aan de volgende eisen.

WAARSCHUWING: Binnenshuis kan dit product radiostoring veroorzaken, in welk geval de gebruiker verplicht kan worden om gepaste maatregelen te nemen.

RFI Emissie

EN55022 Klasse A

WAARSCHUWING: Dit product vereist beschermende kabels in overeenstemming met de limieten van Klasse A emissie. Als het niet met beschermende kabels wordt gebruikt, kan dit product radiostoring veroorzaken, in welk geval de gebruiker verplicht kan worden om gepaste maatregelen te nemen.

Immunititeit

EN50082-1



VEILIGHEID

WAARSCHUWINGEN MET BETREKKING TOT ELEKTRICITEIT

WAARSCHUWING: GEVAAR VOOR ELEKTRISCHE SCHOKKEN

Vervijder het deksel niet, teneinde ELEKTRISCHE schokken te voorkomen. Binnenin bevinden zich geen onderdelen die door de gebruiker onderhouden kunnen worden. Dit toestel staat onder GEVAARLIJKE SPANNING en mag alleen worden geopend door een daartoe opgeleide en bevoegde technicus. Om het gevaar op ELEKTRISCHE SCHOKKEN te vermijden, moet u het toestel van de stroombron ontkoppelen alvorens de LAN-kabels te koppelen of ontkoppelen.



GEVAAR VOOR BLIKSEMINSLAG

GEVAAR: NIET aan toestellen of KABELS WERKEN bij BLIKSEM.

INSTALLATIE

ELEKTRISCH - AUTOMATISCHE AANPASSING VAN DE SPANNING

Dit toestel past zich automatisch aan elke spanning aan, tussen de op het label vermelde waarden.

ELEKTRISCHE TOESTELLEN VAN KLASSE 1

DIT TOESTEL MOET GEAARD WORDEN. De stekker moet aangesloten zijn op een juist geaarde contactdoos. Een onjuist geaarde contactdoos kan de metalen onderdelen waarmee de gebruiker eventueel in aanraking komt onder gevaarlijke spanning stellen.

ELEKTRISCHE SNOEREN

Gebruik een elektrisch snoer, maximum 4,5 meter lang, berekend voor ten minste 6 ampère, 250 V, uit HAR vervaardigd, met aan het ene uiteinde een gevormd IEC 320 aansluitstuk en aan het andere uiteinde een stekker die goedgekeurd is door het land waar het toestel gebruikt zal worden.



OPGELET: De ventilatiegaten mogen niet worden gesperd en moeten de omgevingslucht ongehinderd toelaten voor afkoeling.

BEDRIJFSTEMPERATUUR

De omgevingstemperatuur voor dit product mag niet meer bedragen dan 40 graden Celsius.

ALLE LANDEN: het toestel installeren overeenkomstig de lokale en nationale elektrische voorschriften.

STANDARDIT: Tämä tuote on seuraavien standardien mukainen.

VAROITUS: Kotiolosuhteissa tämä laite voi aiheuttaa radioaaltojen häiriöitä, missä tapauksessa laitteen käyttäjän on mahdollisesti ryhdyttävä tarpeellisiin toimenpiteisiin.

Radioaaltojen häirintä EN55022 Luokka A

VAROITUS: Tämä tuote vaatii suojatut kaapelit täyttääkseen A Luokan säteilyrajoitukset. Ellei suojattuja kaapeleita käytetä, tämä laite voi aiheuttaa radioaallohäreiriöitä, missä tapauksessa laitteen käyttäjän on mahdollisesti ryhdyttävä tarpeellisiin toimenpiteisiin.

Kestävyyys EN50082-1



TURVALLISUUS

SÄHKÖÖN LIITTYVIÄ HUOMAUTUKSIA

VAROITUS: SÄHKÖISKUVAARA

Estääksesi SÄHKÖISKUN älä poista kantta. Sisällä ei ole käyttäjän huollettavissa olevia osia. Tämä laite sisältää VAARALLISIA JÄNNITTEITÄ ja sen voi avata vain koulutettu ja pätevä teknikko.

Vältäaksesi SÄHKÖISKUN mahdollisuuden katkaise sähkövirta tuotteeseen ennen kuin liität tai irrotat paikallisverkon (LAN) kaapelit.



SALAMANISKUVAARA

HENGENVAARA: ÄLÄ TYÖSKENTELE laitteiden tai KAAPELEIDEN KANSSA SALAMOINNIN AIKANA.

ASENNUS

SÄHKÖ—AUTOMAATTINEN JÄNNITTEENSAÄTÖ

Tämä tuote säätää automaattisesti mihin tahansa jännitteeseen ohjetarrassa annettujen arvojen välillä.

SÄHKÖ—TYYPPILUOKAN 1 LAITTEET

TÄMÄ LAITE TÄYTYY MAADOITTAA. Pistoke täytyy liittää kunnollisesti maadoitettuun pistorasiaan. Virheellisesti johdotettu pistorasia voi altistaa metalliosat vaarallisille jännitteille.

SÄHKÖ—JOHTOON LIITTYVÄ HUOMAUTUS

Käytä seuraavanlaista virtajohtoa: maksimipituus 4,5 metriä, minimiteho 6 ampeeria, 250 V, valmistettu HAR-johdostosta, muovattu IEC 320 -liitin toisessa päässä ja käyttömaassa hyväksytty pistoke toisessa päässä.



HUOMAUTUS: Ilmavaihtoreikiä ei pidä tukkia ja niillä täytyy olla vapaa yhteys ympäröivään huoneilmaan, jotta ilmanvaihto tapahtuisi.

KÄYTTÖLÄMPÖTILA

Tämä tuote on suunniteltu ympäröivän ilman maksimilämpötilalle 40°C.

KAIKKI MAAT: Asenna tuote paikallisten ja kansallisten sähköturvallisuusmääräysten mukaisesti.

STANDARD: Questo prodotto è conforme ai seguenti standard.

AVVERTENZA: in ambiente domestico questo prodotto potrebbe causare radio interferenza. In questo caso potrebbe richiedersi all'utente di prendere gli adeguati provvedimenti.

Emissione RFI (interferenza di radiofrequenza) EN55022 Classe A

AVVERTENZA: questo prodotto richiede cavi schermati per adeguarsi ai limiti di emissione per gli apparecchi di Classe A. Se non viene usato con cavi schermati, questo prodotto potrebbe causare radio interferenza, nel qual caso potrebbe richiedersi all'utente di prendere gli adeguati provvedimenti.

Immunità EN50082-1

NORME DI SICUREZZA

AVVERTENZE ELETTRICHE

ATTENZIONE: PERICOLO DI SCOSSE ELETTRICHE

Per evitare SCOSSE ELETTRICHE non asportare il coperchio. Le componenti interne non sono riparabili dall'utente. Questa unità ha TENSIONI PERICOLOSE e va aperta solamente da un tecnico specializzato e qualificato. Per evitare ogni possibilità di SCOSSE ELETTRICHE, interrompere l'alimentazione del dispositivo prima di collegare o staccare i cavi LAN.

PERICOLO DI FULMINI

PERICOLO: NON LAVORARE sul dispositivo o sui CAVI durante PRECIPITAZIONI TEMPORALESCHIE.

INSTALLAZIONE

ELETTRICITÀ—REGOLAZIONE AUTOMATICA DELLA TENSIONE

Questo prodotto regolerà automaticamente la tensione ad un valore compreso nella gamma indicata sull'etichetta.

ELETTRICITÀ—DISPOSITIVI DI CLASSE 1

QUESTO DISPOSITIVO DEVE AVERE LA MESSA A TERRA. La spina deve essere inserita in una presa di corrente specificamente dotata di messa a terra. Una presa non cablata in maniera corretta rischia di scaricare una tensione pericolosa su parti metalliche accessibili.

ELETTRICITÀ—AVVERTENZA SUL CAVO

Usare un cavo della lunghezza massima di metri 4,5, con capacità minima di 6 A, 250 V, di filo HAR, dotato di connettore stampato IEC 320 ad un'estremità e di spina approvata dal paese di destinazione all'altra.

ATTENZIONE: le prese d'aria non vanno ostruite e devono consentire il libero ricircolo dell'aria ambiente per il raffreddamento.

TEMPERATURA DI FUNZIONAMENTO

Questo prodotto è concepito per una temperatura ambientale massima di 40 gradi centigradi.

TUTTI I PAESI: installare il prodotto in conformità delle vigenti normative elettriche nazionali.



SIKKERHETSNORMER: Dette produktet tilfredsstiller følgende sikkerhetsnormer.

ADVARSEL: Hvis dette produktet benyttes til privat bruk, kan produktet forårsake radioforstyrrelse. Hvis dette skjer, må brukeren ta de nødvendige forholdsregler.

RFi stråling

EN55022 Klasse A

ADVARSEL: Det må benyttes isolerte kabler med dette produktet for å tilfredsstille Klasse A strålingsgrenser. Hvis ikke kan dette produktet forårsake radioforstyrrelse. Hvis dette skjer, må brukeren ta de nødvendige forholdsregler.

Immunitet

EN50082-1



**SIKKERHET
ELEKTRISITET**

ADVARSEL: FARE FOR ELEKTRISK SJOKK

For å unngå ELEKTRISK sjokk, må dekslet ikke tas av. Det finnes ingen deler som brukeren kan reparere på innsiden. Denne enheten inneholder FARLIGE SPENNINGER, og må kun åpnes av en faglig kvalifisert tekniker. For å unngå ELEKTRISK SJOKK må den elektriske strømmen til produktet være avslått før LAN-kablene til- eller frakobles.



FARE FOR LYNNEDSLAG

FARE: ARBEID IKKE på utstyr eller KABLER i TORDENVÆR.

INSTALLASJON

ELEKTRISK—AUTO SPENNINGSTILPASNING

Dette produktet vil automatisk bli tilpasset hvilken som helst strømspenning i de områdene som vises på etiketten.

ELEKTRISK—TYPE 1- KLASSE UTSTYR

DETTE UTSTYRET MÅ JORDES. Strømkontakten må være tilkopleet en korrekt jordet kontakt. En kontakt som ikke er korrekt jordet kan føre til farlig spenninger i lett tilgjengelige metalldeleer.

ELEKTRISK—MEDDELELSE OM LEDNINGER

Bruk en strømledning av maksimalt 4.5 m. i lengde, godkjent for minst av 6 amp, 250V, fremstilt av HAR ledning IEC 320 koplingsstykke i den ene enden, og i den andre enden en plugg som er blitt godkjent i brukerlandet.



FORSIKTIG: Lufteventilene må ikke blokeres, og må ha fri tilgang til luft med romtemperatur for avkjøling.

DRIFTSTEMPERATUR

Dette produktet er konstruert for bruk i maksimum romtemperatur på 40 grader celsius.

ALLE LAND: Produktet må installeres i samsvar med de lokale og nasjonale elektriske koder.

PADRÕES: Este produto atende aos seguintes padrões.

AVISO: Num ambiente doméstico este produto pode causar interferência na radiorrecepção e, neste caso, pode ser necessário que o utente tome as medidas adequadas.

Emissão de interferência de radiofrequência EN55022 Classe A

AVISO: Este produto requer cabos protegidos a fim de obedecer aos limites de emissão da Classe A. Se não for utilizado com os cabos protegidos, este produto pode causar interferência na radiorrecepção e, neste caso, pode ser necessário que o utente tome as medidas adequadas.

Imunidade EN50082-1



SEGURANÇA

AVISOS SOBRE CARACTERÍSTICAS ELÉTRICAS

ATENÇÃO: PERIGO DE CHOQUE ELÉTRICO

Para evitar CHOQUE ELÉTRICO, não retire a tampa. Não contém peças que possam ser consertadas pelo usuário. Este aparelho contém VOLTAGENS PERIGOSAS e só deve ser aberto por um técnico qualificado e treinado. Para evitar a possibilidade de CHOQUE ELÉTRICO, desconecte o aparelho da fonte de energia elétrica antes de conectar e desconectar os cabos da LAN.



PERIGO DE CHOQUE CAUSADO POR RAIOS

PERIGO: NÃO TRABALHE no equipamento ou nos CABOS durante períodos suscetíveis a QUEDAS DE RAIOS.

INSTALAÇÃO

ELÉTRICO—AJUSTE AUTOMÁTICO DE VOLTAGEM

Este produto ajustar-se-á automaticamente a qualquer voltagem que esteja dentro dos limites indicados no rótulo.

ELÉTRICO—EQUIPAMENTOS DO TIPO CLASSE 1

DEVE SER FEITA LIGAÇÃO DE FIO TERRA PARA ESTE EQUIPAMENTO. O plugue de alimentação deve ser conectado a uma tomada com adequada ligação de fio terra. Tomadas sem adequada ligação de fio terra podem transmitir voltagens perigosas a peças metálicas expostas.

ELÉTRICO—AVISO SOBRE O CABO DE ALIMENTAÇÃO

Use cabo de alimentação com comprimento máximo de 4,5 metros, com uma capacidade indicada mínima de 6 amp e 250 V, fabricado de material para cabo HAR com conector moldado IEC 320 em uma extremidade e, na outra extremidade, um plugue aprovado para uso no país em questão.

CUIDADO: As aberturas de ventilação não devem ser bloqueadas e devem ter acesso livre ao ar ambiente para arrefecimento adequado do aparelho.



TEMPERATURA DE FUNCIONAMENTO

Este produto foi projetado para uma temperatura ambiente máxima de 40 graus centígrados.

TODOS OS PAÍSES: Instale o produto de acordo com as normas nacionais e locais para instalações elétricas.

ESTÁNDARES: Este producto cumple con los siguientes estándares.

ADVERTENCIA: en un entorno doméstico, este producto puede causar radiointerferencias, en cuyo caso, puede requerirse del usuario que tome las medidas que sean convenientes al respecto.

Emisión RFI

EN55022 Clase A

ADVERTENCIA: este producto requiere de cables armados para cumplir con los límites de emisión de Clase A. Si no se usa con cables armados, este producto puede causar radiointerferencias, en cuyo caso, puede requerirse del usuario que tome las medidas que sean convenientes al respecto.

Inmunidad

EN50082-1



SEGURIDAD

AVISOS ELECTRICOS

ADVERTENCIA: PELIGRO DE ELECTROCHOQUE

Para evitar un ELECTROCHOQUE, no quite la tapa. No hay ningún componente en el interior al cual puede prestar servicio el usuario. Esta unidad contiene VOLTAJES PELIGROSOS y sólo deberá abrirla un técnico entrenado y calificado. Para evitar la posibilidad de ELECTROCHOQUE desconecte la corriente eléctrica que llega al producto antes de conectar o desconectar los cables LAN.



PELIGRO DE RAYOS

PELIGRO: NO REALICE NINGUN TIPO DE TRABAJO O CONEXION en los equipos o en LOS CABLES durante TORMENTAS ELECTRICAS.

INSTALACION

ELECTRICO—AUTO-AJUSTE DE TENSION

Este producto se ajustará automáticamente a cualquier tensión entre los valores máximos y mínimos indicados en la etiqueta.

ELECTRICO—EQUIPO DEL TIPO CLASE 1

ESTE EQUIPO TIENE QUE TENER CONEXION A TIERRA. El cable tiene que conectarse a un enchufe a tierra debidamente instalado. Un enchufe que no está correctamente instalado podría ocasionar tensiones peligrosas en las partes metálicas que están expuestas.

ELECTRICO—ADVERTENCIA SOBRE EL CABLE

Use un cable eléctrico con un máximo de 4,5 metros de largo, con una capacidad mínima de 6 amperios, 250 V, hecho de cable HAR, con el conector moldeado IEC 320 en un extremo y con un enchufe que está aprobado por el país de uso final en el otro.



ATENCION: Las aberturas para ventilación no deberán bloquearse y deberán tener acceso libre al aire ambiental de la sala para su enfriamiento.

TEMPERATURA REQUERIDA PARA LA OPERACIÓN

Este producto está diseñado para una temperatura ambiental máxima de 40 grados C.

PARA TODOS LOS PAÍSES: Monte el producto de acuerdo con los Códigos Eléctricos locales y nacionales.

STANDARDER: Denna produkt uppfyller följande standarder.

VARNING: Denna produkt kan ge upphov till radiostörningar i hemmet, vilket kan tvinga användaren till att vidtaga erforderliga åtgärder.

Radiostörning

EN55022 Klass A

VARNING: Skärnkabel bör användas med denna produkt för att uppfylla kraven gällande radiostörningar enligt Klass A. Om ingen skärnkabel används med denna produkt, kan radiostörningar uppstå, vilket kan tvinga användaren till att vidtaga erforderliga åtgärder.

Immunitet

EN50082-1



SÄKERHET

TILLKÄNNAGIVANDEN BETRÄFFANDE ELEKTRICITETSRIK:

RISK FÖR ELEKTRISK STÖT För att undvika ELEKTRISK stöt, ta ej av locket. Det finns inga delar inuti som behöver underhållas. Denna apparat är under HÖGSPÄNNING och får endast öppnas av en utbildad kvalificerad tekniker. För att undvika ELEKTRISK STÖT, koppla ifrån produktens strömanslutning innan LAN-kablarna ansluts eller kopplas ur.



FARA FÖR BLIXTNEDSLAG

FARA: ARBETA EJ på utrustningen eller kablarna vid ÅSKVÄDER.

INSTALLATION

ELEKTRISKT —AUTOMATISK SPÄNNINGSJUSTERING

Denna produkt justeras automatiskt till alla spänningar inom omfånget som indikeras på produktens märkning.

ELEKTRISKT—TYP KLASS 1 UTRUSTNING

DENNA UTRUSTNING MÅSTE VARA JORDAD. Nätkabeln måste vara ansluten till ett ordentligt jordat uttag. Ett felaktigt uttag kan göra att närliggande metalldelar utsätts för högspänning. Apparaten skall anslutas till jordat uttag, när den ansluts till ett nätverk.

ELEKTRISKT —ANMÄRKNING BETRÄFFANDE KABELN

Använd en kabel med maximum längd 4,5 meter och minimum 6 amp nominal, 250V, av HAR kabelfabrikat med ett specialutformat IEC 320-kontaktidon i ena änden och i den andra en plugg som godkänts i landet där produkten används.



VARNING: Luftventilerna får ej blockeras och måste ha fri tillgång till omgivande rumsluft för avsvälvning.

DRIFTSTEMPERATUR

Denna produkt är konstruerad för rumstemperatur ej överstigande 40 grader Celsius.

ALLA LÄNDER: Installera produkten i enlighet med lokala och statliga bestämmelser för elektrisk utrustning.

Table of Contents

Electrical Safety and Installation Requirements	iii
--------------------------------------------------------------	-----

Chapter 1

Product Description	1
Overview	1
Common Major Features.....	2
Physical Description.....	3
Connectors	3
Front Panel LEDs.....	3
MDI Port	4
Power Supply	5
Required Voltage	5
Auto-Negotiation	5

Chapter 2

Installation	7
Before you Proceed	7
Verifying Package Contents.....	7
Site Requirements	8
Desktop Installation.....	8
Rackmount Installation	9
Configuration	10
Standalone Configuration	10
Cascade Configuration	11
Uplink Configuration	11

Chapter 3

Troubleshooting	13
Connectivity Testing	13
Problem Solving.....	14
Is the unit receiving power?.....	14
Is the Link/Activity LED lit?	14

Appendix A

Switch Specifications	17
Physical Characteristics.....	17
Standards.....	17
Cabling Specifications.....	18
Electrical Specifications.....	18
UTP (RJ45) Connector.....	18
Low Last Bit-to-First Delay.....	18
Network Specifications.....	19
100Base-TX Cable.....	19
100Base-TX Connector Pinouts.....	20
Straight-through Cable.....	20
Crossover Cable.....	20

Appendix B

Technical Support Fax Order	21
Incident Summary.....	21

Appendix C

AT-FS708 and AT-FS708E Switches Installation Feedback	23
--------------------------------------------------------------------	----

Appendix D

Where To Find Us	25
-------------------------------	----

Chapter 1

Product Description

Overview

This chapter describes the features of the following unmanaged Fast Ethernet switches:

- ❑ AT-FS708
- ❑ AT-FS708E

Each switch model is described in Table 1:

Table 1 Switch Models and Port Description

Model	Description
AT-FS708	Eight auto-negotiating 10/100 Mbps twisted pair RJ45 ports Port 8 MDI and Port 8 MDI-X Total bandwidth of 800 Mbps Internal Power Supply
AT-FS708E	Eight auto-negotiating 10/100 Mbps twisted pair RJ45 ports Port 8 MDI and Port 8 MDI-X Total bandwidth of 800 Mbps External Power Supply

Note

For definitions of technical terms associated with Allied Telesyn's products, refer to the Glossary on Allied Telesyn's website at www.alliedtelesyn.com.

Common Major Features

These switches come with the following common features:

- ❑ IEEE 802.3 and IEEE 802.3u compliant
- ❑ RJ45 ports that can be connected/disconnected without powering off the switch
- ❑ Store and forward switching at full-wire speed (14,880 packets per second on 10 Mbps ports and 148,880 packets per second on 100 Mbps ports)
- ❑ Media-dependent interface (MDI) on Port 8 MDI for hub connection or Port 8 MDI-X for PC connection
- ❑ Support for up to 8K MAC addresses
- ❑ Internal power supply (100-120/200-240VAC) for AT-FS708, or external power adapter for AT-FS708E
- ❑ Desktop or rackmounting (rackmount option for AT-FS708 only)

The switch models described in this guide complement the other Allied Telesyn Fast Ethernet products, providing simple, cost-effective solutions for switching between 10 and 100 Mbps. Easy to install, simply connect your 10Base-T or 100Base-TX station ports, and plug in the power.

Figures 1 and 2 show the front panels of the switches.



Figure 1 AT-FS708 Front Panel



Figure 2 AT-FS708E Front Panel

Physical Description

The physical description for the switches includes:

- Connectors
- Media-Dependent Interface (MDI), Port 8
- LEDs
- Power supply

Connectors

Table 2 lists and defines the type of connectors available and their function.

Table 2 Connector Types on Switches

Connector Type	Function
Ports 1 through 8 10Base-T/100Base-TX RJ45 connectors	Connecting to a high performance workstation, server, or hub

Front Panel LEDs

Figure 3 shows the front panel LEDs; Table 3 describes the LED status.

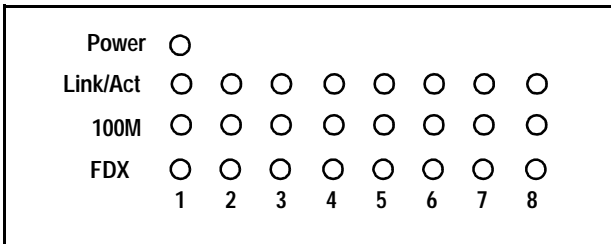

Figure 3 A Close Up of the Front Panel LEDs

Table 3 LED Status

LEDs	Color	Description
LINK/ACTIVITY	Green	On indicates a valid physical link on the port. Blinking indicates data is being transmitted. Off means no link.
100M	Green	Off means the bandwidth is 10 Mbps. On means the bandwidth is 100 Mbps.
FDX (FULL-DUPLEX)	Green	On indicates full-duplex transmission mode. Off indicates half-duplex transmission mode.
POWER	Green	Off means there is no power to the switch. On means there is power to the switch.

MDI Port

Port 8 is associated with the MDI function.

Port 8 gives you the flexibility of using a straight-through cable to connect to a hub or another switch (Port 8 MDI), or to any DTE device (Port 8 MDI-X), such as an end station or a server.

Note

Use only one Port 8, either Port 8 MDI or Port8 MDI-X.

Table 4 MDI Ports

Port	Use
Port 8 MDI	To connect a hub or another switch to the port
Port 8 MDI-X	To connect a DTE to the port

Power Supply

The AT-FS708 uses a 40W universal internal switching power supply with 100 to 120 VAC, or 200 to 240 VAC, 50/60 Hz input rating.

Allied Telesyn ships power cords with the units to the U.S., Continental Europe, and the U.K.

The AT-FS708E uses an external power adapter.

Required Voltage

The switches require input of 100 to 230 VAC. Maximum power consumption is 50W maximum.

Auto-Negotiation

The 10/100 Mbps ports are capable of auto-negotiation:

The ports automatically adapt to the wire speed (10 or 100 Mbps) and duplex transmission (half- or full-duplex) supported by the linked device without user reconfiguration.

Auto-negotiation is an optional function of the IEEE 802.3u Fast Ethernet standard that enables devices (switches) to automatically exchange information over a link about their speed and duplex abilities. This allows devices to perform automatic configurations to achieve the maximum common level of operation over a link. Auto-negotiation can provide automatic speed matching for multispeed devices at each end of a link. Multispeed Ethernet interfaces can then take advantage of the highest speed offered by the 10/100 ports on the switch.

The auto-negotiation protocol also includes automatic negotiation of duplex mode, allowing auto-negotiation-capable end-system devices to not only configure the speed but also change to full-duplex for even higher traffic throughput. This is particularly useful in environments where NICs are being replaced or desktop workstations are moved. Each time a new device is connected to a switch's port or a device is moved from one port to another, auto-negotiation will automatically reconfigure each port without any intervention from a network administrator.

Chapter 2

Installation

Before you Proceed

Before installing the switch, make sure you read “Electrical Safety and Installation Requirements” on page iii.

Verifying Package Contents

Make sure that the package includes the following items:

- One AT-FS708 or AT-FS708E switch
- One AC power cord (AT-FS708) or power adapter (AT-FS708E)
- Two rackmounting brackets with screws (AT-FS708 only)
- Four self-adhesive rubber feet
- Warranty card
- This installation guide

If any of the above items is damaged or missing, contact your representative immediately.

Site Requirements

Make sure you observe the following site requirements:

- ❑ Make sure you are placing the switch in a dust-free and moisture-free environment.
- ❑ Do not block ventilation openings on the unit. Allow at least 10 cm (4 in) of space at the front and back of the unit for ventilation.
- ❑ Make sure that the switch's power is accessible and cables can be connected easily.
- ❑ Cabling should be away from sources of electrical noise such as radios, transmitters, broadband amplifiers, power lines, and fluorescent fixtures.
- ❑ Do not place objects on top of the switch.
- ❑ Use dedicated power circuits or power conditioners to supply power to the switch.

Desktop Installation

Place the switch on the desktop using these steps, or perform the steps "Rackmount Installation" on page 9. The AT-FS708 (only) can be stacked two or more devices high on the desktop as described in the steps below.

1. Attach the four self-adhesive rubber feet to the bottom of the switch, positioning them in the indentations.
2. Place the switch on a flat, level surface where power is easily accessible.
3. To stack more than one switch (for the AT-FS708 only), repeat step 1 for the additional switches before stacking them. The rubber feet cushion the switch against shock and vibration and provide space between each switch for ventilation.
4. Connect power:
 - For AT-FS708, attach one end of the power cord to the back of the switch and the other end to the power source.
 - For AT-FS708E, plug the power adapter into the power receptacle, then plug the DC connector to the switch.

Note

The switch performs a self-diagnostic test upon power on, and takes about 20 seconds to complete.

5. Make sure the Power LED on the front panel lights green.
6. Attach the data cables and observe normal operation as indicated by the port LEDs. Use only one Port 8, either Port 8 MDI or Port 8 MDI-X.

Rackmount Installation

Rackmount installation applies to the AT-FS708 only. You will need a Phillips screwdriver for this installation.

Caution

Do not use power tools to perform this installation.

1. If previously attached, remove the rubber feet and all cables and power cord from the switch.
2. Attach the rackmounting brackets to each side of the switch, using the screws provided.
3. Attach the power cord to the back of the switch.
4. Position the switch in a standard 19-inch rack and secure the switch's brackets to the rack using the 4 large screws provided.
5. Plug the power cord into the power receptacle. Make sure the Power LED on the front panel lights green.
6. Attach the data cables and observe normal operation as indicated by the port LEDs. Use only one Port 8, either Port 8 MDI or Port 8 MDI-X. For typical configuration information, refer to "Configuration" on page 10.

Note

Auto-negotiation for transmission mode supports full-duplex only if the connected device also negotiates for full-duplex transmission mode.

You are finished with rackmount installation.

Configuration

The following sections discuss standalone, cascade and uplink configurations.

Standalone Configuration

Figure 4 shows the switch connected to end stations and a server. The basic physical connection for this configuration requires connecting one of the switch's ports to the adapter card of an end station.

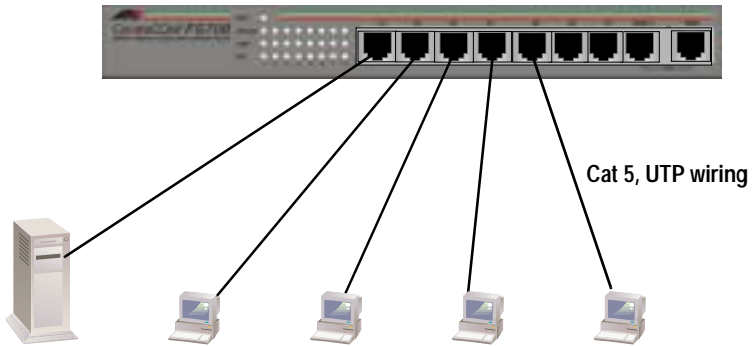

Figure 4 AT-FS708 Connected to End Stations

Cascade Configuration

Cascading means that two switches can be connected together using any of the switch ports provided you maintain the same medium type. Two switches can be cascaded to support multiple network port connections. Cable length to the nodes must follow the 100Base-TX cabling specifications.

To cascade installed switches, do the following:

Note

When cascading switches, you must use the same medium type from port to port.

1. If you intend to use Port 8, use Port 8 MDI.
2. Use a straight-through UTP RJ45 cable to connect the first switch to the second switch. See Figure 5.

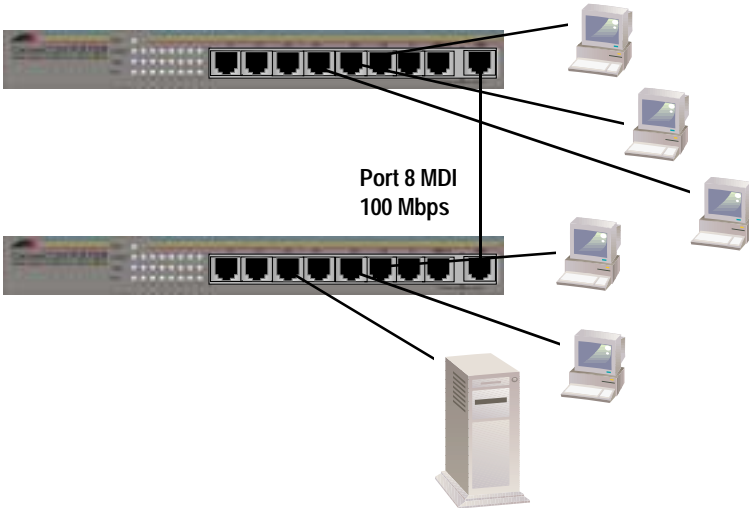

Figure 5 Cascading Switches

3. Check the front panels to make sure that the green Link/Activity LED lights.

Uplink Configuration

For 100 Mbps connection to the backbone, use Port 8 MDI.

Figure 6 illustrates how the AT-FS708 switches can be used as an uplink to the backbone in a typical office complex using Category 5 UTP cable.

CORPORATE BACKBONE

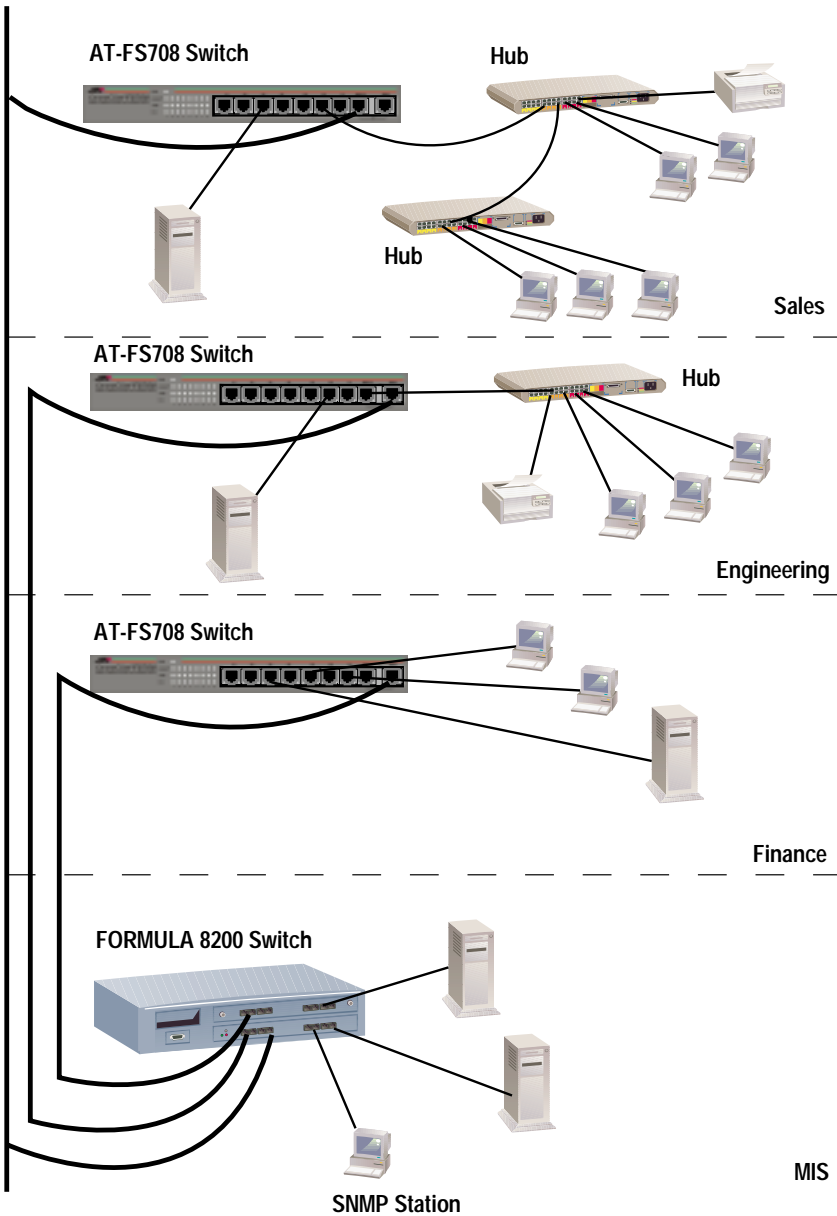

Figure 6 Switches as Uplink to the Backbone

Chapter 3

Troubleshooting

This chapter describes the procedures to test and troubleshoot the switches.

Connectivity Testing

In the following procedure, you will test each port for a valid connection and to confirm the correct operation of the network.

1. Start with Ports 1 and 2. Connect these two ports of a single switch to two nodes or workstations and turn on the switch power.
2. Wait approximately 1-3 seconds for the auto-negotiation process to complete after power-on or after the cables are reconnected.
3. Make sure the Link/Activity and other LEDs of both switch ports are lit.
4. After confirming that Port 1 and Port 2 are operational, reconnect one of the nodes/workstations to another port, then repeat this connectivity test with the switch's remaining ports. Continue to verify the connection in each port by checking the Link/Activity and other activity LEDs.

Note

Use Port 8 MDI-X connected to a workstation. Use Port 8 MDI connected to a hub. Use only one Port 8 at a time.

Problem Solving

Is the unit receiving power?

Check the Power LED on the front of the switch. This green LED should be lit.

Note

The switch performs a self-diagnostic test upon power on, and takes about 20 seconds to complete.

If the Power LED is not on, check both ends of the power cord or adapter. Make sure the power cord or adapter is plugged into a functioning wall outlet and that it is properly inserted into the switch's connector on the back of the unit.

Is the Link/Activity LED lit?

The Link LED on the front of the switch lights when a proper connection between the corresponding 10/100Base-TX port and the equipment connected to it is established. If this LED is not lit, check for the problems listed below and make corrections as necessary.

1. **Problem 1:**

The cable has been cut, damaged, or it is the wrong type of cable.

Solution 1:

- Try making the connection with a different cable. Be sure you are using an undamaged cable of the correct type.

2. **Problem 2:**

Connected equipment is not turned on or not operating properly.

Solution 2:

- Check the connected equipment (computer, another switch, etc.) and turn on the power.

3. **Problem 3:**

Port 8 does not work.

Solution 3:

- Connect to only one Port 8, either Port 8 MDI or Port 8 MDI-X. Make sure you are connected to the correct Port 8.

4. Problem 4:

There is data loss between the switch and one of the connected network nodes.

□ Solution 4:

- **Make sure that the distance between the switch and the connected network device is no greater than 100 m (328 ft).**
- **Make sure you are using Category 5 cable.**

Appendix A

Switch Specifications

Physical Characteristics

Chassis Dimensions:

AT-FS708 9.81 in (W) x 4.5 in (D) x 1.5 in (H)
249 mm (W) x 114 mm (D) x 38 mm (H)

AT-FS708E 7.75 in (W) x 4.56 in (D) x 1.44 in (H)
197 mm (W) x 116 mm (D) x 37 mm (H)

Weight:

AT-FS708 3.65 lbs (1.9 kg)

AT-FS708E 1.4 lbs (0.64 kg)

Operating temperatures: 0° to 40° C (32° to 104° F)

Storage temperatures: -40° to 70° C (-40° to 158° F)

Relative humidity: 5% to 95% (non-condensing)

Operating altitude: Up to 10,000 ft (3,048 m)

Standards

CE Compliant

Functional: IEEE 802.3 10Base-T Ethernet
IEEE 802.3u, 100Base-TX Fast Ethernet

EMI/RFI: Meets FCC Class A, VCCI Class A, CISPR
Class A

Safety: Conforms to all standards normally supported
by Allied Telesyn products, including safety
standards UL 1950, CSA/NRTL (C22.2 950,
UL 1950), TUV/GS (EN60950)

Immunity: IEC 1000-4-2/3/4/6

Cabling Specifications

10Base-T:	STP/UTP Category 3,4,5 100 ohm impedance
100Base-TX:	STP/UTP Category 5 wiring, 100 ohm impedance

100 m (328 ft) between switch and network node.

Electrical Specifications

AT-FS708 Internal Power:	Internal universal power supply with 100 to 240 VAC, 50/60 Hz, 0.3 A input.
AT-FS708E External Power:	External power adapter provides 13-19 UDC, 800 mA maximum.

UTP (RJ45) Connector

Figure 7 shows an RJ45 connector. For a 100Base-TX link between switches, —any two Medium Attachment Units (MAUs)—you need a crossover cable. For a connection to a Network Interface Controller (NIC), the cable is wired straight-through.

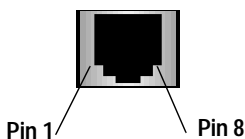

Figure 7 RJ45 Connector

Low Last Bit-to-First Delay

For long packets:	<30 μ s
For short packets:	<18 μ s

Network Specifications

Table 5 provides an overview of IEEE 802.3 and 802.3u specifications for 10Base-T and 100Base-TX network configurations using shielded twisted-pair wiring.

Table 5 IEEE 802.3 and 802.3u Network Specifications

	10Base-T	100Base-TX
Media	Shielded Twisted Pair Category 3 or 5	Shielded Twisted Pair Category 5 only
Topology	Star, Tree	Star, Tree
External Devices	Network Adapter Card, Repeater	Network Adapter Card, Repeater
Maximum Segment Length	100 m (328 ft)	100 m (328 ft)

100Base-TX Cable

There are various grades of voice-quality and data-quality cables available. These can appear to be similar externally, although their high-speed data transmission characteristics are radically different.

The identification problem is made worse by some suppliers selling voice-quality cables as data-quality cables.

If voice-quality cables are used in a 100Base-TX network system, data movement may be slow, collision-prone or non-existent. In addition, interface LEDs will usually indicate a valid link in such cases.

Category 5 is required cabling for use with 100Base-TX connections. Using any other category for a 100Base-TX connection may have high error rates and may not have the capacity to transmit data.

100Base-TX Connector Pinouts

Straight-through Cable

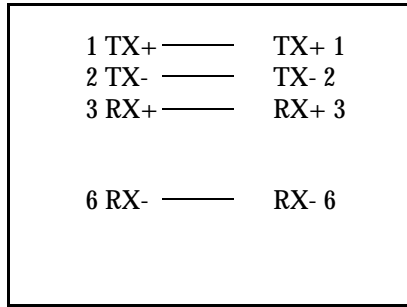

Crossover Cable

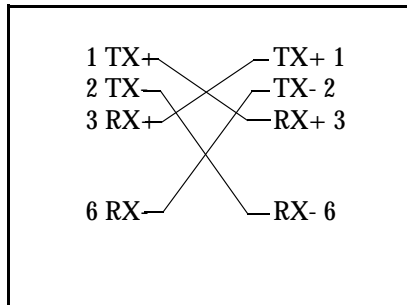

Appendix B

Technical Support Fax Order

Name _____

Company _____

Address _____

City _____ State/Province _____

Zip/Postal Code _____ Country _____

Phone _____ Fax _____

Incident Summary

Model number of Allied Telesyn product I am using _____

Network software products I am using _____

Brief summary of problem _____

Conditions (List the steps that led up to the problem.) _____

Detailed description (Use separate sheet, if necessary)

When completed, fax this sheet to the appropriate Allied Telesyn office. Fax numbers can be found on page 25.

Appendix C

AT-FS708 and AT-FS708E Switches Installation Feedback

Please tell us what additional information you would like to see discussed in the guide. If there are topics you would like information on that were not covered in the guide, please photocopy this page, answer the questions and fax or mail this form back to Allied Telesyn International Corp. The mailing address and fax number are at the bottom of the page. Your comments are valuable when we plan future revisions of the guide.

I found the following the most valuable _____

I would like the following more developed _____

I would find the guide more useful if _____

Please fax or mail your feedback. Fax to 1-408-736-0100. Or mail to:
Allied Telesyn International, Corp.
c/o Technical Communications
960 Stewart Drive, Suite B
Sunnyvale, CA 94086 USA

Appendix D

Where To Find Us

For Technical Support or Service		
Location	Phone	Fax
Americas United States, Canada, Mexico, Central America, South America	1 (800) 428-4835	1 (918) 628-3222
Asia Singapore, Taiwan, Thailand, Malaysia, Indonesia, Korea, Philippines, China, India	(+65) 3815-613	(+65) 3833-830
Australia Australia, New Zealand	(+61) 2-943-5111	(+61) 2-9438-4966
France France, Belgium, Luxembourg, The Netherlands, Middle East, Africa	(+33) 1-60-92-15-32	(+33) 1-69-28-37-49
Germany Germany, Switzerland, Austria, Eastern Europe	(+49) 30-435-900-126	(+49) 30-435-70-650
Hong Kong	(+852) 2-529-4111	(+852) 2 529-7661
Italy Italy, Spain, Portugal, Greece, Turkey, Israel	(+39) 02-416047	(+39) 02-419282
Japan	(+81) 3-3443-5640	(+81) 3-3443-2443
United Kingdom United Kingdom, Denmark, Norway, Sweden, Finland, Iceland	(+44) 1-235-442560	(+44) 1-235-442680
Technical Bulletin Board Service	1 (425) 483-7979	
Technical Support E-mail Address	TS1@alliedtelesyn.com	
CompuServe	Go ALLIED	
FTP Server	Address: ftp.alliedtelesyn.com [lowercase letters] Login: anonymous [lowercase letters] Password: your e-mail address [requested by the server at login]	

For Sales or Corporate Information Regarding Allied Telesyn International, Corp.

Allied Telesyn International, Corp.

19015 North Creek Parkway
Bothell, WA 98011
Tel: 1 (425) 487-8880
Fax: 1 (425) 489-9191

Allied Telesyn International, Corp.

960 Stewart Drive, Suite B
Sunnyvale, CA 94086
Tel: 1 (800) 424-4284 (USA and Canada)
Fax: 1 (408) 736-0100

World Wide Web:

<http://www.alliedtelesyn.com>

